

# Renault TRAFIC CPL CONVERSION

Renault Conversions, Tailor Made Solutions for your Business





# Renault Trafic Access Platform - Tailor Made Solutions

The Renault Trafic Access Platform adaptations are part of Renault's Tailor Made range that has been developed to compliment our 'Off the Shelf' Conversions. The Tailor Made range offers a standard specification based on the expert collaboration between Renault and our accredited converter partners. The specifications have been developed to meet common requirements however, they can be adapted to suit specific customer requirements, providing a truly tailor made solution.

Our accredited range has been developed in partnership exclusively with converters who have attained Renault converter accreditation after being assessed on their technical and quality standards by a dedicated team from Renault. A list of these can be found at [www.conversions.renault.co.uk](http://www.conversions.renault.co.uk) All of our Tailor Made conversions are available to order directly via our Dealer Network.

For more information please contact  
[conversions@renault.co.uk](mailto:conversions@renault.co.uk)

## Powerful, clever and dynamic

The Trafic Van has been specifically designed to meet the needs of professionals, whatever their business environment. In panel van, crew van and passenger versions, the Trafic can be adapted to your every demand, offering a wide range of custom-built and practical solutions, plus the ability to create other variations using the Platform Cab version as a base. With its stylish and protective design, efficient engines, the latest on-board technology and high levels of comfort and improved safety, the Trafic holds all the cards.





# Renault Traffic Features and Options

The K21 Renault Traffic Access Platform has been designed to provide its users with the best possible partner for Urban projects. With its compact size and no outrigger design, this conversion will eliminate the usual frustrations of setting up and manoeuvring.

The K21 Renault Traffic Access Platform has an impressive working height of 9.2m and working outreach of 5.8m. With no outriggers and a working load of 120Kg in the basket, this one-man conversion will drastically cut down job preparation time. The boom rotates to 360° allowing for a great access range.

All of the CPL van mounted Access Platforms can be operated with the engine switched off and a green pack installed. This provides control of the access platform using just the battery.

CPL offers a multitude of optional specs to suit any project. These include; Front, rear and cab beacons, work lights, reversing cameras, internal electric sockets, company livery and chapter 8 markings. These can all be installed at the factory by skilled technicians."



## Hill Start Assist

This feature allows the vehicle to be held on an incline, without the use of the handbrake, for two seconds. This allows you time to engage gear and apply power.



## Electronic Stability Control

This features helps you avoid collisions by detecting and reducing the danger of skidding or losing control as a result of over-steering.



## Grip Xtend

Engaging Grip Xtend over loose surfaces such as gravel, light snow and shallow mud allows the front wheels to spin. This spinning action clears away the low grip surface and allows you to gain traction on the higher grip surface below.

# Technical Specification

- Working Height: 9.2m
- Working Outreach: 5.8m
- Basket Capacity: 120Kg – 1 man
- Boom Rotation: 360 degrees
- Access Platform Hour Counter fitted
- Engine stop/start from basket
- Emergency electric pump in basket
- Aluminium Boom for maximum stability

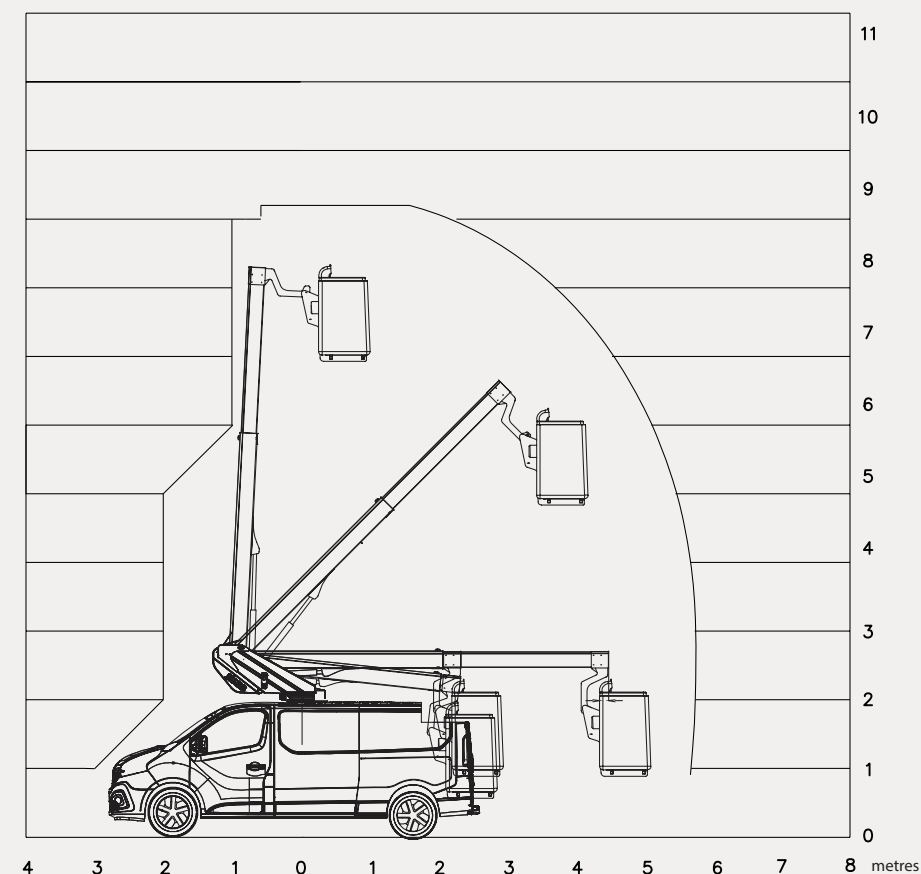

# Contact



38b Telford Way Industrail Estate,  
Kettering, Northamptonshire,  
NN16 8UN

+44 (0)1536 529876

info@cpl-ltd.com

www.cumberlanduk.co.uk

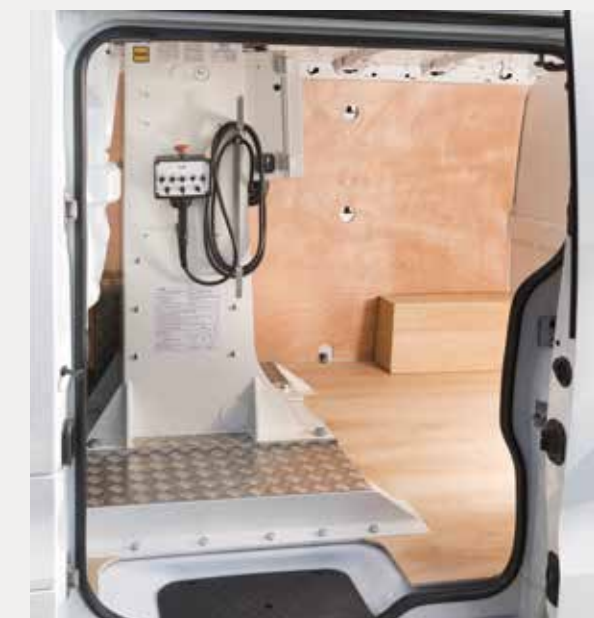

# Renault Traffic Features and Options

## THE BASICS

- Electric front windows
- 80-litre fuel tank
- 20-liter AdBlueR tank
- Door mirrors – heated with electric adjustment and external temperature sensors
- ESC (Electronic Stability Control) with Hill Start Assist and Grip Xtend
- Alarm
- ABS with EBD (Electronic Brake force Distribution)
- Electronic immobiliser
- Remote central locking (2 button key)
- Deadlocking
- 4 disc brakes
- Passenger bench seat

## MAKING YOUR JOURNEY COMFORTABLE

- Closed glove box
- Driver's seat with armrest – height adjustable, lumbar adjustment
- Adjustable steering wheel

## WHAT YOUR VAN LOOKS LIKE

- 16" DELOS wheel trims
- Unglazed left side loading door
- Unglazed, 180° rear doors
- Roof bar fixings+

## KEEPING YOU CONNECTED

- 2x15W DAB radio with AUX input, CD, Bluetooth® and USB connectivity\*\*
- Trip computer – multifunctional
- Eco mode function
- 12V power socket (front)

## PROTECTING YOU AND YOUR LOAD

- Anchorage points: 16 for SWB and 18 for LWB
- Full steel bulkhead\*
- Spare wheel with anti-theft spare wheel holder

\*Excluding Crew Van and Platform Cab \*\*For compatible devices, please refer to <https://www.renault.co.uk/services/multimedia/bluetooth-compatibility.html> †Excluding platform cab

Continue the Renault Conversions experience  
at [www.renault.co.uk](http://www.renault.co.uk)



For more information please contact [conversions@renault.co.uk](mailto:conversions@renault.co.uk)

Although every effort has been made to ensure that the information contained within this brochure is as accurate and up to date as possible, Renault U.K. reserves the right to modify its models without notice, including their characteristics, specifications, equipment and accessories. Brochures inevitably become out of date or inaccurate in some respects, in that such characteristics, specifications equipment, or accessories may be changed after the publication date given below and can differ from the descriptions given or the photos displayed. It is therefore necessary to check with your Renault Dealer before purchasing any product that the characteristics, specifications, equipment or accessories of the vehicle on order are as advertised. The colours that appear in this document may differ slightly from the actual paint and upholstery colours.

Renault recommends 

 Prodigious

Photo credits: © Renault Marketing 3D-Commerce, A. Bernier, R. Richter, S. Agnetti, O. Banet, D. Meunier – Printed in EC – 7 August 2018